

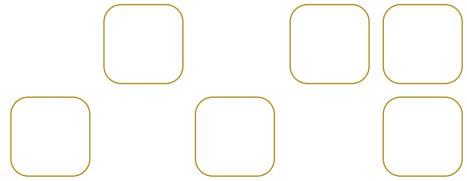

# AIR PRESSES PN Series

## 空壓壓床 PN系列



**鎖固螺絲**  
Fixing screw

**下壓行程調整組**  
PS：鎖固螺絲需放鬆。  
**Adjustable locknuts**  
P.S:Fixed screw must be loosened.

**工作台調整輪**  
調整工作台上下高度。  
**Manual adjustable wheel**  
Adjust working height.

**專利氣控閥組**  
結合調壓、過濾、給油、電磁閥一體，  
維修保養容易。

**Patent pneumatic control combination**  
Combining filter, regulator, lubrication  
and solenoid valves, easy to maintain  
and repair.

**計數器**  
歸零功能，能了解每日生產量，便於  
管理了解成本。  
**Counter**  
To estimate production and control cost.

**計時器**  
控制壓配的時間。  
**Timer**  
Control pressure time.

**定時開關**  
開啓為控制動作時間  
關閉為手動控制。  
**Timer switch**  
On~control active time,  
Off~manual control.

**電源**  
啓動／關閉開關。  
**Power**  
On/Off switch.

**安全按鈕**  
需左右一起按下才能操作壓床作動。  
**Hand safety push button control**  
Left and right button must be controlled  
together to operate the press.



# PN-200/300/500/800/1000H

按鈕控制 / Push button control

## 規範 / Specifications:

規格 Model	PN-200	PN-300	PN-500	PN-800	PN-1000													
連接座 (整組可調) Z-axis travel (Adj)	160 (mm)	160 (mm)	160 (mm)	180 (mm)	180 (mm)													
最大工作高度 (可調) Maximum working height	200 (mm)	200 (mm)	200 (mm)	350 (mm)	350 (mm)													
氣缸規格 Cylinder bore x stroke	Ø63 x75 (mm)	Ø80 x100 (mm)	Ø100 x100 (mm)	Ø125 x100 (mm)	Ø150 x100 (mm)													
氣缸可調行程 Adjustable cylinder stroke	標準Standard 25 (mm) / 選用Option 50 (mm)																	
工作檯面積 Table area	150 x 150 (mm)	180 x 200 (mm)	180 x 200 (mm)	250 x 250 (mm)	250 x 250 (mm)													
電源 Power	AC110/220 V, 50/60 Hz																	
操作壓力 Operating pressure	0.4~0.7Mpa(4~7kg/cm <sup>2</sup> )																	
操作壓力 Air pressure	理論出力Theoretical Output																	
	Mpa	kg / cm <sup>2</sup>	psi	N	kg	lb	N	kg	lb	N	kg	lb	N	kg	lb	N	kg	lb
0.4	4	57	1098	112	247	1775	181	400	2883	294	649	4413	450	992	6580	671	1479	
0.5	5	71	1373	140	309	2226	227	500	3609	368	811	5521	563	1241	8218	838	1848	
0.6	6	85	1648	168	371	2668	272	600	4335	442	974	6620	675	1488	9866	1006	2218	
0.7	7	100	1922	196	433	3109	317	699	5051	515	1136	7728	788	1737	11513	1174	2588	

- 實際出力約為理論出力之80%。  
Output force exerted approx. 80% of theoretical output.

型式 TYPE	A	B	C	D	E	F	G	H	I	J	ØK	L	M	N	ØP	ØQ	R	S	T
PN-200	360	75	80	150	200~125	80	35	80	230	(最大 MAX660)	40	150	162	190	16	25	15	30	M8X1.25
PN-300	400	100	100	200	200~100	80	25	150	345	(最大 MAX780)	60	180	210	230	16	30	20	40	M10X1.5
PN-500										(最大 MAX780)					19	35			
PN-800	600	100	125	250	350~250	100	35	180	410	(最大 MAX986)	80	250	270	330	19	35	20	40	M10X1.5
PN-1000										(最大 MAX996)					25	40			

## 外型尺寸圖 / External Dimensions

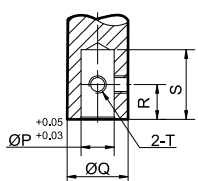

● A 部詳圖，比例3:1  
● A Block, Scale 3:1

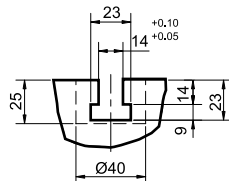

● B 部詳圖，比例3:1  
● B Block, Scale 3:1

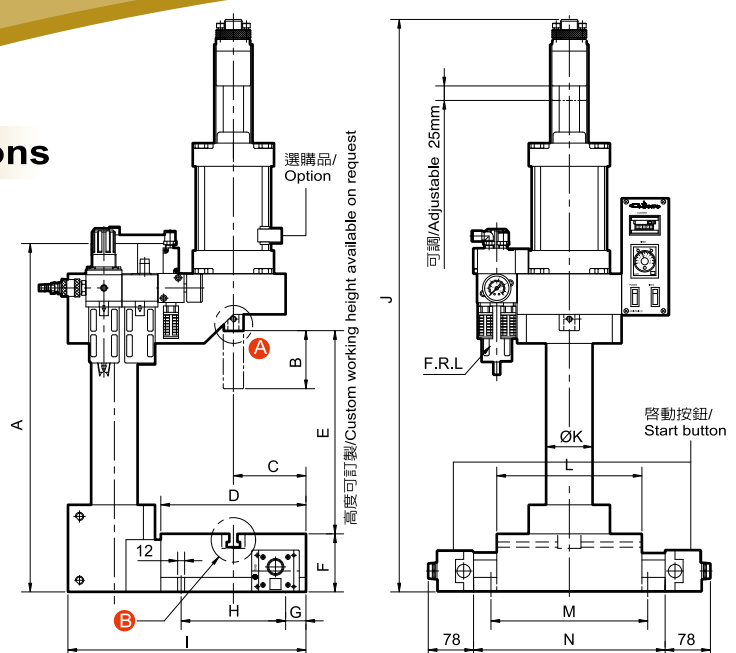

- 模治具與工作尺寸需列入考慮。 The height of mould & workpiece should be taken into account.
- 特殊規格能承製，請洽本公司。 Custom specifications are available.
- 可加裝下降行程確認信號。 Option sensor for inducing stroke location.