

PND-02T 按鈕控制 Push button control

規範/Specifications:

規格 Model	PND-02
最大工作高度 (可調) Maximum working height	302 (mm)
氣缸規格 Cylinder bore x stroke	Ø150 x100 - 2 (mm)
氣缸可調行程 Adjustable cylinder stroke	標準/Standard 選用/Option 25 (mm) 50 (mm)
工作檯面積 Table area	350 x 240 (mm)
電源 Power	AC110/220 V, 50/60 Hz
操作壓力 Operating pressure	0.4~0.7Mpa(4~7 kg / cm ²)

操作壓力 Air pressure			理論出力 Theoretical Output		
Mpa	kg / cm ²	psi	N	kg	lb
0.4	4	57	13160	1342	2958
0.5	5	71	16436	1676	3696
0.6	6	85	19732	2012	4436
0.7	7	100	23026	2348	5176

- 實際出力約為理論出力之80%。
Output force exerted approx. 80% of theoretical output.



外型尺寸圖/External Dimensions

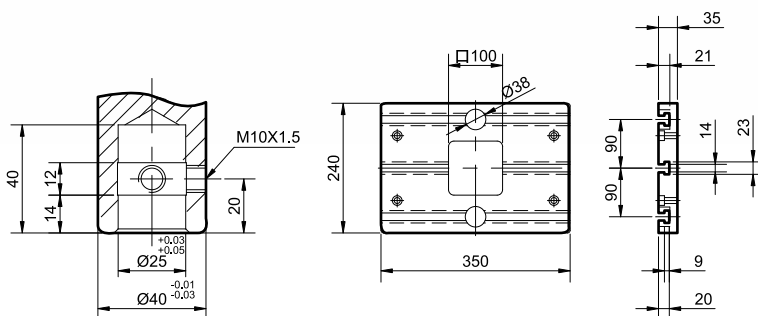

A 部詳圖，比例5:1
A Block, Scale 5:1

B 部詳圖，比例1:1
B Block, Scale 1:1

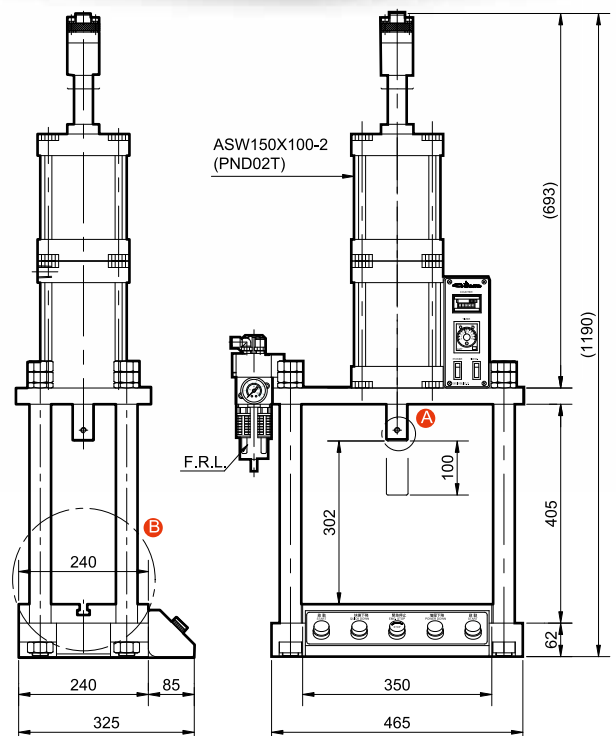

- 模治具與工作尺寸需列入考慮。The height of mould & workpiece should be taken into account.
- 特殊規格能承製，請洽本公司。Custom specifications are available.